

# Digital Drum

## Owner's Manual

# INFORMATION FOR YOUR SAFETY!

## THE FCC REGULATION WARNING (for USA)

This equipment has been tested and found to comply with the limits for a Class B digital device, pursuant to Part 15 of the FCC Rules.

These limits are designed to provide reasonable protection against harmful interference in a residential installation. This equipment generates, uses, and can radiate radio frequency energy and, if not installed and used in accordance with the instructions, may cause harmful interference to radio communications. However, there is no guarantee that interference will not occur in a particular installation.

If this equipment does cause harmful interference to radio or television reception, which can be determined by turning the equipment off and on, the user is encouraged to try to correct the interference by one or more of the following measures:

- Reorient or relocate the receiving antenna.
- Increase the separation between the equipment and receiver.
- Connect the equipment into an outlet on a circuit different from that to which the receiver is connected.
- Consult the dealer or an experienced radio/TV technician for help.

Unauthorized changes or modification to this system can void the user's authority to operate this equipment.

### CAUTION

The normal function of the product may be disturbed by Strong Electro Magnetic Interference. If so, simply reset the product to resume normal operation by following the owner's manual. In case the function could not resume, please use the product in other location.

## PRECAUTIONS

### PLEASE READ CAREFULLY BEFORE PROCEEDING

Please keep this manual in a safe place for future reference.

#### Power Supply

Please connect the designated AC adaptor to an AC outlet of the correct voltage.

Do not connect it to an AC outlet of voltage other than that for which your instrument is intended.

Unplug the AC power adaptor when not using the instrument, or during electrical storms.

#### Connections

Before connecting the instrument to other devices, turn off the power to all units. This will help prevent malfunction and / or damage to other devices.

#### Location

Do not expose the instrument to the following conditions to avoid deformation, discoloration, or more serious damage:

- Direct sunlight
- Extreme temperature or humidity
- Excessive dusty or dirty location
- Strong vibrations or shocks
- Close to magnetic fields

#### Interference with other electrical devices

Radios and televisions placed nearby may experience reception interference. Operate this unit at a suitable distance from radios and televisions.

#### Cleaning

Clean only with a soft, dry cloth. Do not use paint thinners, solvents, cleaning fluids, or chemical-impregnated wiping cloths.

#### Handling

Do not apply excessive force to the switches or controls.

Do not let paper, metallic, or other objects into the instrument. If this happens, remove the electric plug from the outlet. Then have the instrument inspected by qualified service personnel.

Disconnect all cables before moving the instrument.

# Contents

<b>Main Features</b> .....	4	<b>The Drum Pad Triggers Settings</b>	
<b>Panel &amp; Display Description</b>		About the Drum Pad Trigger Settings.....	17
Front Panel.....	5	Save the Drum Pad Trigger Settings.....	18
Side Panel.....	6	<b>Utility Settings</b> .....	19
LCD Display.....	7	<b>Using Usb Flash Drive (Usb Memory)</b>	
<b>Setup</b>		Sample Load.....	20
Connecting Pads and Pedals.....	8	Kit Save.....	21
<b>Getting Ready to Play</b>		Kit Load.....	21
Setting Up the Power Supply.....	9	Format.....	21
Turning the Power On/off.....	9	<b>Factory Set</b> .....	22
<b>Drum Kits and Voices</b>		<b>MIDI</b>	
Selecting a Drum Kit.....	10	About MIDI.....	23
Selecting a Voice.....	10	Making the MIDI Settings.....	23
Playing Techniques.....	10	Connecting with an External Sound Device.....	23
<b>Select a Preset Drum Kit and Create a User Drum Kit</b>		Using the Digital Drum as a Sound Module.....	24
About the Preset and User Drum Kit.....	12	<b>Troubleshooting</b> .....	25
Edit the Drum Kit Parameters.....	12	<b>Prompt Messages</b> .....	25
Edit the Voice Parameters.....	12	<b>Specifications</b> .....	26
About the User Voice.....	13	<b>Appendix</b>	
Save User Drum Kit.....	13	Drum Kit List.....	27
<b>Playing Along with a Song</b>		Drum Voice List.....	28
Playing Along with a Song.....	14	Song List.....	31
Metronome.....	15	GM Drum Kit List.....	33
Starting/Stopping the Metronome.....	15	GM Melody Voice List.....	39
Adjusting the Tempo Value.....	15	MIDI Implementation Chart.....	40
<b>Record</b>			
Prepare Recording.....	16		
Start /Stop Recording.....	16		

# Main Features



## PURE DRUM Technology

No matter playing the pads with softly stroke or forcefully passion grooves, with this new technology, all performances can show up extremely wide range of velocity dynamics. Perfectly express the various changes of acoustic drums, all of these let you enjoy the real delicate nuances, capture the unique characteristics of acoustic drum kit from the PURE DRUM!

## PURE DRUM—Bring the Natural and Realistic Voices to Your Performance!

With our unique PURE DRUM technology, which has vastly improved sound quality for digital drums, will reach a super natural and realistic sense for your ears. No matter playing the stroke roll or striking pads with velocity dynamic, all of these let you enjoy delicate nuances and natural voice, capture the unique characteristics of acoustic drum kit.

## Simulating the Real Drum Pads and Cymbals

Our engineers are always keeping keen on simulating the real drum kit, this time we have redefined our previous pad designing, specialized surface material, even with superb trigger sensitivity, hand-feeling and mute function. Simulate various play effects: head/ bow shot, rim shot, ride, damper and so on. This creates a new era of digital drum.

## Enjoy Playing with the USB Songs

Support directly playing songs (WAV and MP3 format) from the USB flash , even you can freely playing with the USB song, just enjoy your music.

Or play with the background music via the AUX IN terminal and instantly record/ save your perfect performance to the USB disk.

## Download Your Favorite Voices to Drum Module

Via the USB function, you can download your favorite wave samples (no matter download from the internet or soft sound source) to digital module and use them as the internal voices. This makes your drum voices limitless any more, try and experience this exciting function.

## Steady Elegant Appearance

Equipped with full lattice LCD display and data dial, sufficiently shows the professional and user experience features.

# Panel & Display Description

## Front Panel

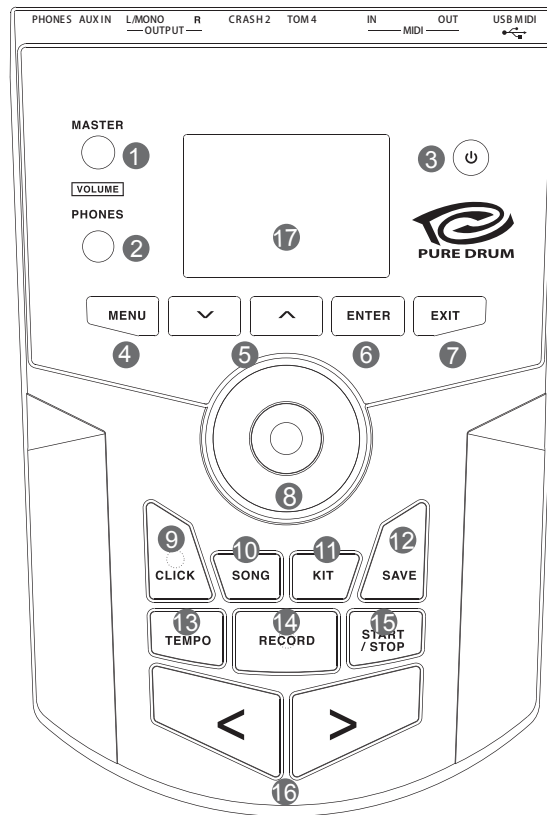

1. **[MASTER VOLUME] Knob**  
Adjust the output volume level.
2. **[PHONES] Knob**  
Adjust the phones volume level.
3. **[POWER] button**  
Press this button to power on/ off the module.
4. **[MENU] Button**  
Enter menu mode.
5. **[CURSOR +]/ [CURSOR -] Button**  
Select a specified item by moving the cursor position up/down.
6. **[ENTER] Button**  
Enter the selected menu.
7. **[EXIT] Button**  
Exit current menu and back to previous menu.
8. **DATA DIAL**  
Use this to select drum kits or to quick edit values (increase/decrease value, select specified item).
9. **[CLICK] Button**  
Start/Stop the metronome, enter the metronome parameter setting.
10. **[SONG] Button**  
Enter Song mode.
11. **[KIT] Button**  
Enter the Drum Kit mode.
12. **[SAVE] Button**  
Save the drum kit/ pad settings.
13. **[TEMPO] Button**  
Adjust the tempo value.
14. **[RECORD] Button**  
Enter the quick record mode.
15. **[START/STOP] Button**  
Start/ Stop playing back songs.
16. **[<]/ [>] Button**  
Gradually increasing or decreasing the parameter value, also can be used to select kit, pad, and song parameters.
17. **LCD Display**  
Shows the name and parameter settings of Kit, Voice, Song and so on.

## Panel & Display Description

### Rear Panel

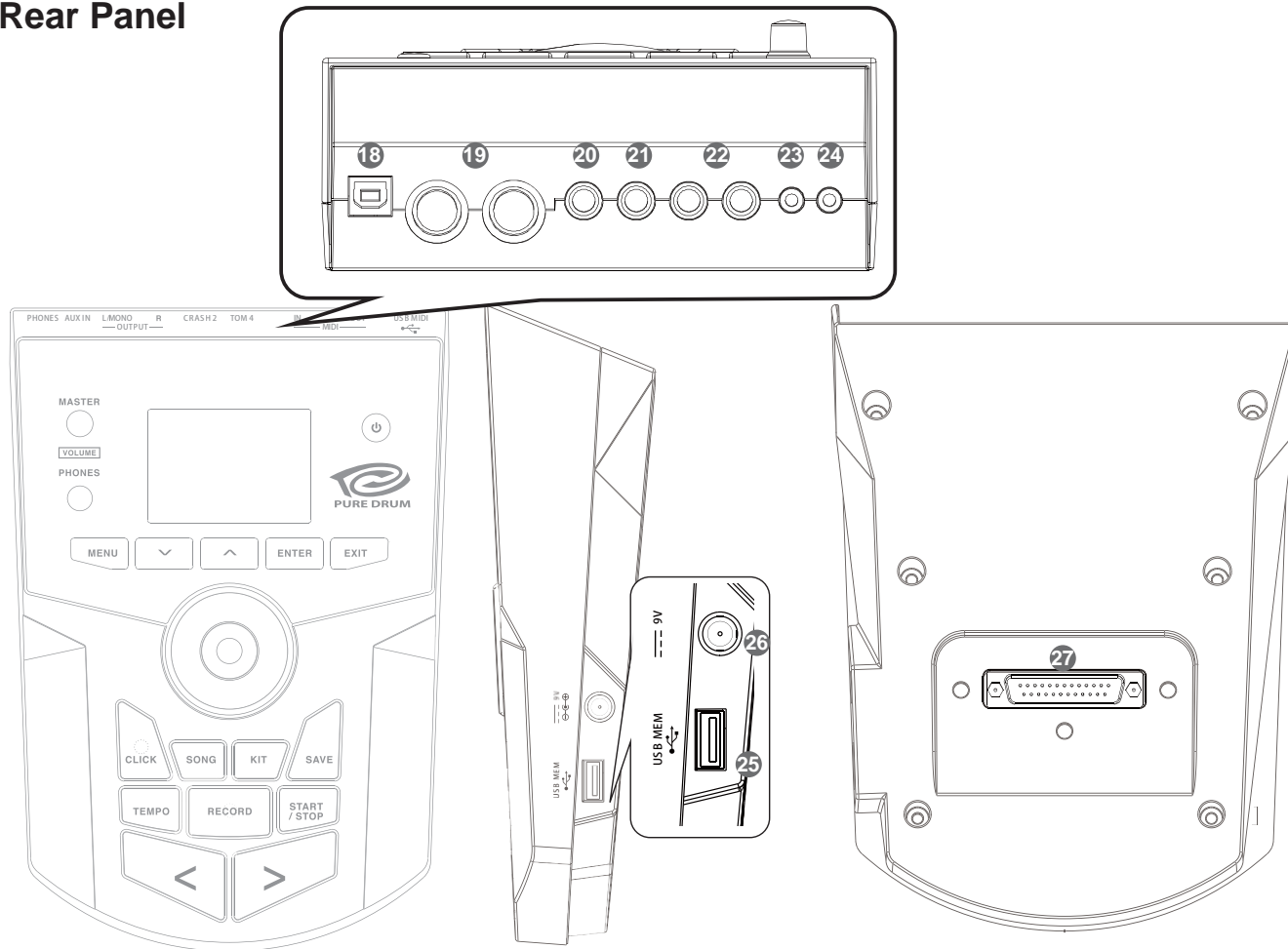

#### 18. USB Terminal

Use this when you want to connect a PC/laptop or USB host device.

**Note:** Only transmit MIDI data.

#### 19. MIDI Terminal (IN, OUT)

Use this to connect extra MIDI sequencer, transmit MIDI data.

**MIDI IN Connector:** receive MIDI data; you can receive MIDI data from an extra MIDI device or a PC/laptop.

**MIDI OUT Connector:** send MIDI data; you can send MIDI data to an extra MIDI device or a PC/laptop.

#### 20. TOM 4 jack (1/4")

This allows you to connect additional Tom 4.

#### 21. CRASH 2 jack (1/4")

This allows you to connect additional Crash 2.

#### 22. OUTPUT jack (L/MONO, R) (2 x1/4")

Connect to your audio system or amplifier. For stereo output use both the L/MONO and R jacks. For monaural output use the L/MONO jack.

#### 23. AUX IN jack (1/8")

For connecting an extra audio player, for example, MP3 and so on via a stereo plug. You can enjoy playing the drum along with your favorite songs.

#### 24. PHONES jack (1/8")

Connect stereo headphones here. Detecting all output sounds.

#### 25. USB Flash Drive port

Insert your USB flash drive here, and play back audio files from it. Or save setting data on it.

#### 26. DC IN jack

Connect the AC adaptor here. Plug the AC adaptor cable into the DC IN jack.

#### 27. TRIGGER INPUT CONNECTOR terminal

Connect the included dedicated cable to this connector, and use it to connect the pads and pedals.

# Panel & Display Description

## LCD Display



### 1. Menu Item

Display the current menu, such as “KIT”, “VOICE”, “SONG”, “TRIGGER”, “UTILITY” and so on.

### 2. Trigger Pad Name

Display current selected Trigger pad name, such as “KICK”, “SNARE”, “SN-R”, “TOM1”, “T1-R” and so on.

### 3. Prompt Move Cursor Up/ Down

Prompt to view more parameters by pressing cursor up/down button.

#### Prompt Enter

Prompt that you can enter current menu item for more settings.

### 4. External Device

Indicate external device when it is correctly connected.

### 5. Strength of the pad strike

Display the strength of the pad you strike.

### 6. The Main Parameter Information

Display current main parameter information, as the picture shows.

### 7. Detailed Parameter Value

Corresponding to main parameter, list detailed parameters.

# Setup

## Caution!

To prevent electric shock and damage to the device, make sure the power is switched OFF on the drum and all related device before making any connection.

## Connect the Pads and the Pedals

**Standard configuration:** KICK, SNARE (Dual-zone trigger), TOM 1~3(Dual-zone trigger), CRASH1 (Dual-zone trigger with choke), RIDE (Triple-zone trigger with choke), HI-HAT, HI-HAT CONTROL PEDAL.

### Note:

1. Using the cables provided, connect each Trigger input jack on the rear panel of the module, and make sure each pad is connected to its corresponding trigger input jack.
2. For details on assembling the drum stand, attaching the digital drum and connecting pads, refer to the *Installation Manual* description.

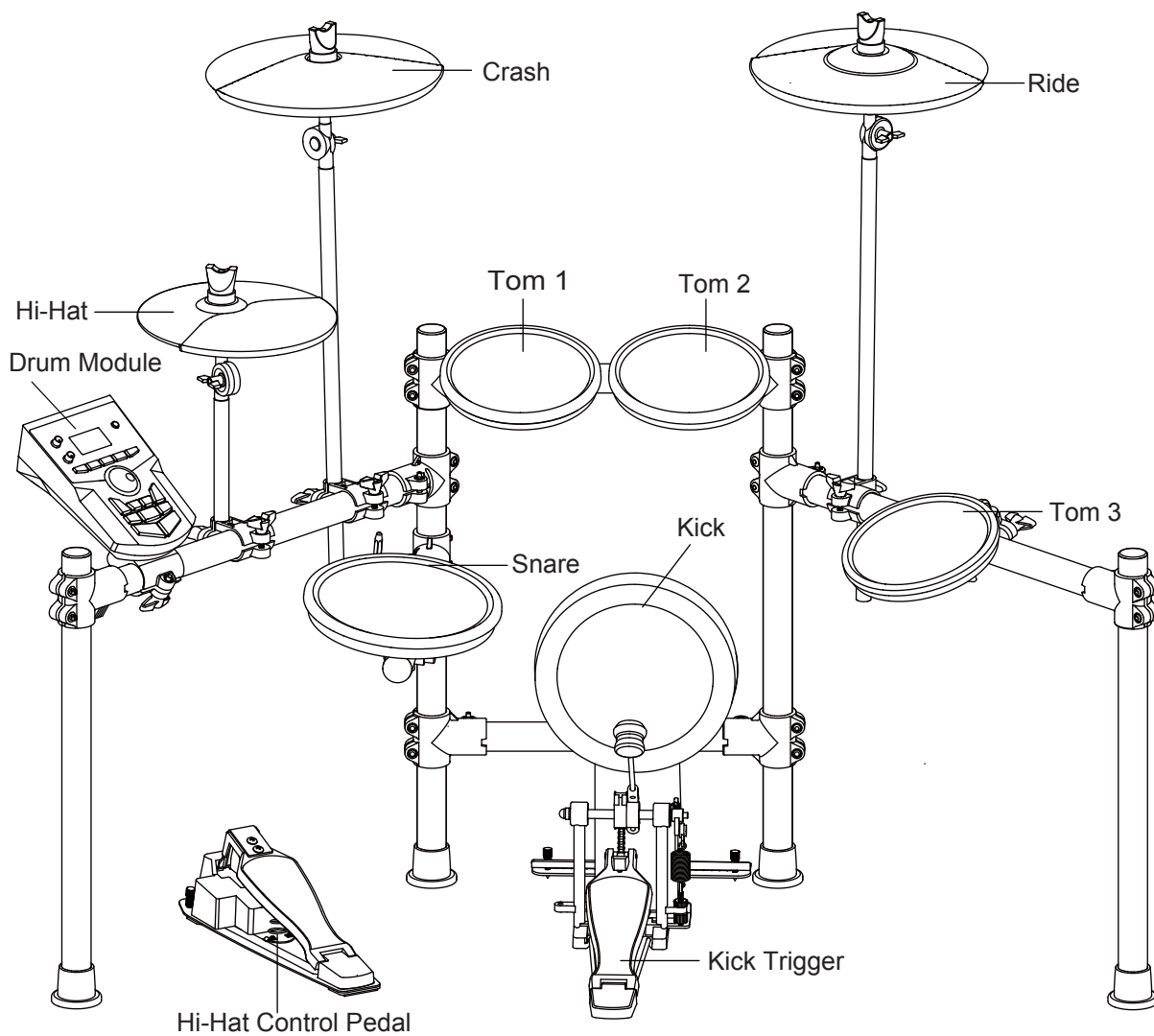

# Getting Ready to Play

## Setting up the Power Supply

1. Connect the DC plug of the AC power adaptor to the DC IN jack on the rear panel.
2. Connect the other end of the power cord to the AC outlet.

### Note:

1. Only use the voltage specified as correct for the drum module.
2. Even when the module is turned off, electricity is still flowing to the module at the minimum level. When you are not using the drum module for a long time, make sure to unplug the AC power adaptor from the wall AC outlet.

## Turning the Power On/Off

### Turning the power on

Make sure that you have made all necessary connections (trigger, audio and so on), turn down all volume controls of the module and other audio equipments.

1. Turn both the [VOLUME] knobs always to minimize the volume.
2. Press the [POWER] button.
3. Turn the amplifier or audio system on, or listen to the headphones.
4. Striking the pads and adjust the volume by slowly turning the [PHONES VOLUME] and [MAIN VOLUME] knob towards the right direction. Keep turning until you get an appropriate value.

MASTER



VOLUME



### Turning the power off

1. Minimize the volume of the module and audio device.
2. Turn the connected external audio device off.
3. Keep pressing the [POWER] button until the power is turned off.

### Hint:

You can restore the factory set by following steps:

- a) Press the [<] and [>] buttons simultaneously.
- b) Press [POWER] button.
- c) Until the LCD displays "FactoryResetting...". Complete reset operation, the module will return to the KIT MENU.

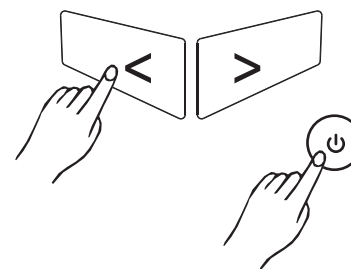

Factory  
Resetting...

### About the Auto Power Off Function

For purpose of energy conservation and environmental protection, this function automatically turns the power off if there isn't any operation (eg, playing, striking, button pressing and so on) for about 30 minutes. You can enable or disable this function as you like. Refer to **Utility Settings**.

# Drum Kits and Voices

An acoustic drum has only a fixed kit, but the digital drum set has a lot. It is a particular characteristic of digital drum.

The structure of a drum kit showed on the right:

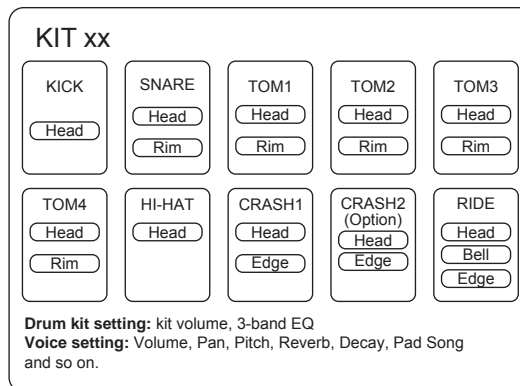

## Selecting a Drum Kit

1. Press the [KIT] button, enter drum kit menu.

The screen shows on the right:

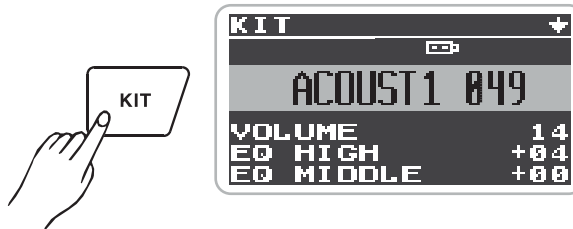

2. Press the [<] / [>] button or data dial, select your desired drum kit. (Refer to **Drum Kit List**)

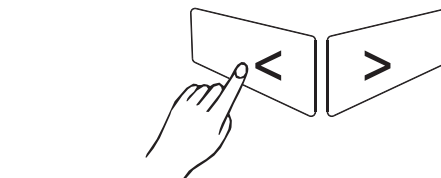

## Selecting a Voice

While striking the pads, you can enjoy the ensemble sound effect. If you are not satisfied with the voice of any pads, change the voice as you want.

1. In the KIT menu, press the [MENU] button. Select the "VOICE" item and then press the [ENTER] button to enter the voice menu. The screen display is shown on the right:



2. Strike the pad you want. The screen will display the name of current pad.

3. While striking the pad, press the [<] / [>] button or data dial until you get an appropriate voice for your pads. (Refer to **Voice List**)



## Playing Techniques

This section introduces various performance functions to make your performance professional. Similar to an acoustic drum kit, the digital drum responds differently to various playing techniques and dynamics. All the pads are velocity sensitive. And some voices change timbre depending on the striking force.

### Pad

Only the snare drum can detect both head shot and rim shot.

### Head Shot

Strike only the head of the pad.

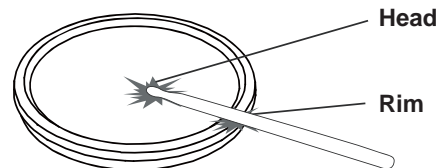
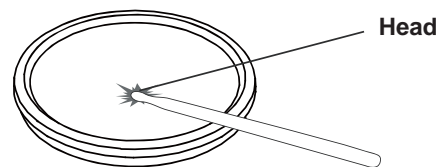

# Drum Kits and Voices

## Rim Shot

Strike the head and the rim of the pad simultaneously. Or you can only strike the rim of the pad.

## Cymbal

### Cymbal Bow Shot

Strike the middle area of the cymbal. As shown in the figure.

### Cymbal Edge Shot

Strike the edge area of the cymbal. As shown in the figure.

### Cymbal Bell Shot

Strike the bell area of the cymbal. As shown in the figure.

### Choke Play

Both Ride and Crash cymbals have cymbal choke. But hi-hat don't have the cymbal choke.

Choking the crash/ride edge with the hand immediately after hitting the crash/ride mutes the crash/ride sound.

## Hi-Hat

### Hi-Hat Pedal Change

With different positions the pedal pressed down, the voice of pad varied while you are striking the Hi-Hat pad. And this is similar to an acoustic drum.

### Open Hi-Hat

Strike the Hi-Hat pad without pressing the pedal.

### Closed Hi-Hat

Strike the Hi-Hat pad with the pedal pressed completely down.

### Hi-Hat Pedal

Press down the hi-hat controller's pedal to create a foot-close sound without having to strike the hi-hat pad.

## Splash

Playing the hi-hat with the pedal fully pressed and then instantly releasing it.

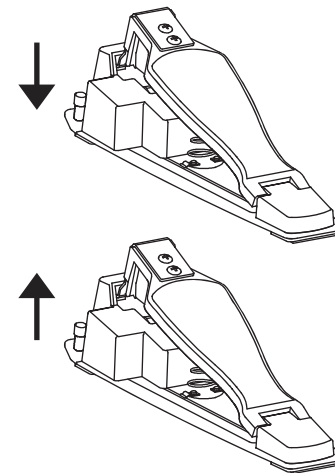
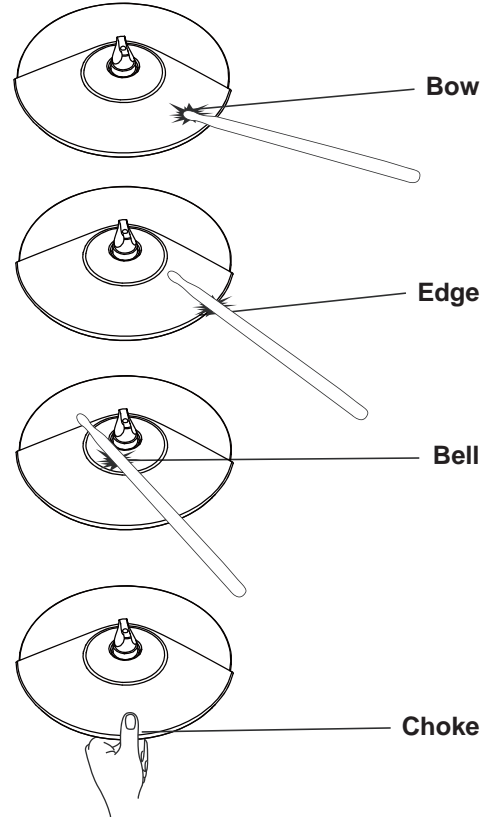

# Select a Preset Drum Kit and Create a User Drum Kit

## About the Preset and User Drum Kit

From no.1 to 50 are preset drum kits, and the drum kits from no.51 to 70 are user drum kits. You can edit the parameters of drum kit (from no.1-70), and save them into user drum kits (from no.51-70).

### Note:

Please save your own parameter or voice after edited, otherwise, all data will be lost.

## Edit the Drum Kit Parameters

Change the drum kit volume, the overall effect of drum kit will be affected. It means if you increase the volume of drum kit, all volume of the pads will be increased.

1. Press the [KIT] button, the LCD displays the first page of kit menu.

Press the [KIT] button again will quickly enter the user drum kit menu: KIT51.

### Note:

The character “\*”, in front of the kit name, indicates that the data of user kit still keep the default value even after the reset operation.

(Please refer to the **Kit List**)

2. Press the [^]/[v] button to select the item that you want to edit.

Parameter	Value	Description
KIT NAME	Preset: 1~50 User: 51~70	Drum kit selection.
VOLUME	0~16	Adjust the volume of drum kit; the volume of each pad will be changed.
EQ HIGH	-12(dB)~12(dB)	Adjust the gain (amplitude change) in the EQ high frequency band.
EQ MID	-12(dB)~12(dB)	Adjust the gain (amplitude change) in the EQ middle frequency band.
EQ LOW	-12(dB)~12(dB)	Adjust the gain (amplitude change) in the EQ low frequency band.

3. Use the [<]/[>] button or data dial to adjust parameter value.

## Edit the Voice Parameters

Editing parameters of one pad will not affect others. For example, if you increased the volume of a snare pad, the other pads wouldn't change their parameters.

1. Press the [KIT] button, and then press the [MENU] button later.

Use the [^]/[v] button to select the “VOICE” item, press the [ENTER] button to enter VOICE menu.

2. Press the [^] button and use data dial or [<]/[>] button to select the pad that you want to edit. Or you can directly strike the specified pad.

3. Press the [^]/[v] button to select the item that you want to edit.

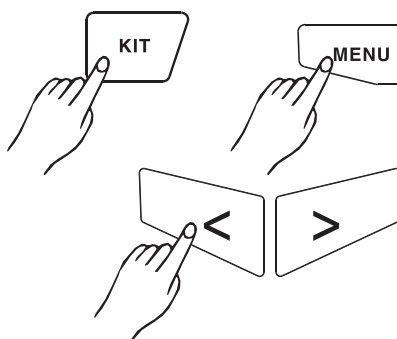
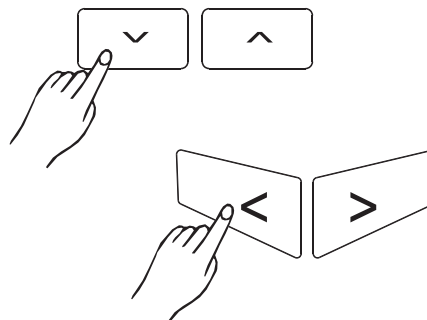
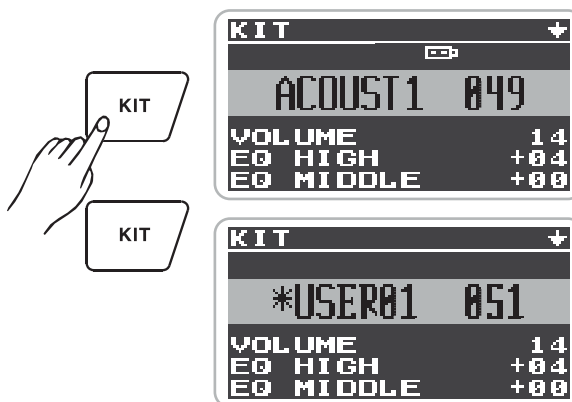

## Select a Preset Drum Kit and Create a User Drum Kit

Parameter	Value	Description
TRIGGER	KICK, SNARE, SN-R, TOM1, T1-R...	Select the trigger input.
VOICE NAME	1~628, U01~U99	Select a voice. The U01~U99 represent user voice which download form USB flash drive.
VOLUME	0~16	Adjust the volume of voice.
PAN	-8~ +8	Adjust the pan of voice.
PITCH	-8~ +8	Adjust the pitch of voice.
REVERB	0~16	Adjust the reverb of voice.
DECAY	-5~0	Adjust the decay of voice.
PAD SONG	Off, 1-120	Switch the pad song on/off and choose the song number.

### About the User Voice

You can download the wave samples which you like from USB flash drive into the module. We call them as "User Voice". The "User Voice" were used as same as the Preset Voices in module.

1. Use the [<] / [>] button or data dial to adjust parameter value.

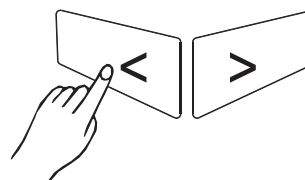

### Save User Drum Kit

Please save your own parameter or voice after edited, otherwise, all data will be lost.

1. While in the drum kit and voice edit menu, pressing the [SAVE] button to enter user drum kit saving page.
2. Use the [<] / [>] button or data dial to select a user drum kit. Press the [ENTER] button to confirm save operation.
3. Temporally display "Save OK!" about 2~3 seconds, and then back to KIT.

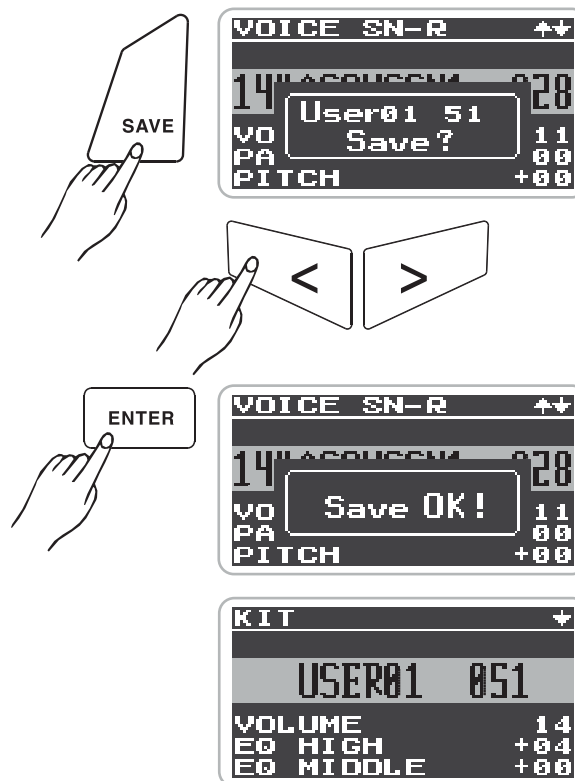

**Note:**

The character "\*" in front of the kit name will disappear after saving.

# Playing Along With a Song

There are up to 120 songs with variety of styles, including 70 Patterns, 10 Hits, 40 Taps, and 5 User songs (Refer to the **Song List**). You can play the drums while listening to one of these songs.

A song contains Drum part and Accompaniment part. Drum part means the rhythm you played on the pads; the Accompaniment part means percussion and melody. The volume of each part can be adjusted.

## Playing Along With a Song

1. Press the [SONG] button to enter the selection menu.

Parameter	Value	Description
NUMBER	1~125 U01~U99	The number of songs: 1~60: Preset Patterns. 61~70: Preset Percussion loop. 71~80: Preset Hit 81~120: Preset Tap 121~125: User Song. U01~U99: WAV/MP3/MIDI files from SONG folder on the USB.
ACCOM VOL	0~16	Accompaniment volume.
DRUM VOL	0~16	Drum volume.



2. Press the [^]/[V] button to select the item that you want to edit. Use the [<]/[>] button to adjust parameter value.

3. Press the [START/STOP] button to play/stop songs.

4. In SONG menu, press the [SONG] again, switch between preset and USB flash drive songs. The menu of USB flash drive song:

Press the [START/STOP] button to play back WAV, MP3 or MIDI files. The buttons [^]/[V] and [<]/[>] are used to move the cursor position.

Temporarily display "Processing...", and then begin playing the selected song, the first line displays time or beat.

5. In the SONG menu, press the [MENU] button to enter SONG MENU. Press the [^]/[V] button to select the item that you want to edit.

6. Press the [^]/[V] button to select the "USB FOLDER" item, and then press [ENTER] button to display the folders of USB flash drive, open folders and display the song files (It will auto back to this folder even being switched to other menu.).

The module will load the songs from the default folder "SONG" in USB flash drive. Please accord to the operations above to enter related folder, if the mp3 songs located at other folder.

Up to 99 MP3/ WAV/ MIDI songs can be displayed in a folder. If you have more than 99 MP3/ WAV/ MIDI songs on USB flash drive, please arrange them in different folders.



# Playing Along With a Song

Format requires:

1. MIDI SONG: SMF 0, track number should be less than 16, PPQN ≤480, MIDI file size ≤128k byte.
2. WAV: Bit rates : ≤ 1536kbps, Sampling rates: ≤ 48kHz
3. MP3: Bit rates: ≤320kbps, Sampling rates: ≤48kHz.
4. Besides above formats, there will pop up an error message.

## Metronome

Practicing with the metronome is the best way to follow the beats. Choose a right tempo for your learning/ performance requirement.

### Starting/ Stopping the Metronome

1. Press the [CLICK] button.

The metronome starts playing, and the button light will blink at the current tempo. (Current time signature will be displayed on top of LCD.)

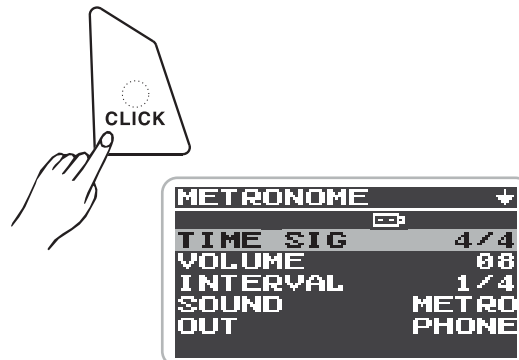

2. Press the [^]/ [v] button to select the item that you want to edit. Use the [<]/ [>] button or data dial to adjust parameter value.

Parameter	Value	Description
TIME	0-9/2, 0-9/4,	Adjust the time signature.
SIGNATURE	0-9/8, 0-9/16	
VOLUME	0~16	Adjust the volume of metronome.
INTERVAL	1/2,3/8,1/4,1/8, 1/12,1/16	Adjust the rhythm interval.
CLICK NAME	METRO, CLAVES, STICKS, COWBELL, CLICK, VOICE	Select metronome voice which you want. There are totally 6 metronome voice types.
OUTPUT	PHONES ALL (PHONES+ OUTPUT)	Select the destination of metronome output.

3. Press the [CLICK] button again to stop the metronome, the light will be off, and the display will return to the screen before entering CLICK MENU.

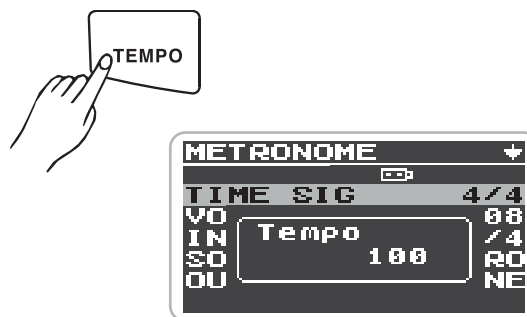

### Adjusting the Tempo Value

1. Press the [TEMPO] button.

2. Use the [<]/ [>] button or data dial to adjust parameter value.

**Note:**

Temporarily display tempo value about 3 seconds, automatically back to the original mode.

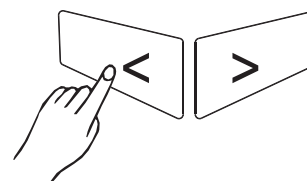

# Record

In this chapter, we will introduce how to use this digital drum to record your own performance.

There are two methods to record: record as MP3 format or MIDI format.

- a) When using an USB flash drive, auto record your own performance as MP3 files, up to 99 user songs can be recorded to an USB flash drive.
- b) Without an USB flash drive, auto record your own performance as MIDI files, up to 5 user songs can be recorded in this drum module flash drive.

About how to prepare and start recording, please refer to the details bellow:

## Prepare Recording

Before recording a song, you can preset these parameters as you like: Tempo, Kit, Time Signature, Interval and Song if background music needed.

After [RECORD] button pressed, please choose one position from USER SONG 121~125 to save the recorded song.

If the USB flash drive has been plugged, the recorded song will be mp3 format and will be automatically saved to the USB flash drive.

## Start / Stop recording

1. You can start recording in real time while in the prepare recording menu, there are two ways to start recording:  
Press the [START/STOP] button.  
Strike one pad.
2. If you want to exit recording in the prepare recording menu, just one way as below.  
Press the [RECORD] button again.

### Note:

1. In Song menu, press the [RECORD] button, recording performance with accompaniment playing.
2. In Kit menu, press the [RECORD] button, only recording your drum part performance.
3. While recording, the [RECORD] button keeps lighting all the time and "RECORDING--" displays on the LCD.
4. Press the [START/STOP] button again to stop recording, and the [RECORD] button light will be off.

The recordings will be saved and the LCD displays "Saving...". When saved successfully, the system will return to record folder.

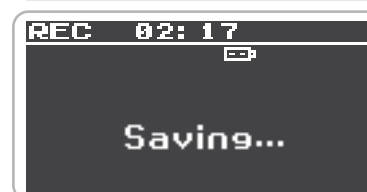
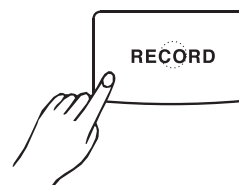

# The Drum Pad Triggers Settings

## About the Drum Pad Trigger Settings

As a professional drummer, you may be very pleased to set your drum triggers carefully corresponding to your playing habits and feelings, making your performance more interesting and professional. In the meantime, your digital drum will be more operable.

1. In the KIT menu, select the “TRIGGER” item.
2. Press the [^]/[v] button to select the trigger parameters that you want to edit.

The drum pad trigger settings are shown below:

Parameter	Value	Description
SENSITIVITY	1~16	The sensitivity of the pads can be adjusted to satisfy your personal preference. If you adjust the sensitivity parameter to a high value, even a soft strike can produce loud sound. If you adjust the sensitivity parameter to a low value, even heavy strikes only produce low sound.
RIM SEN	1~16	Adjust the sensitivity of rim shot.
HEAD-RIM ADJ	1~16	Adjust the disturbance between head and rim shot.
THRESHOLD	1~16	The threshold of the pads means a specified signal level, and only the trigger signal above it can be sounded. This setting can prevent some unwanted sounding, such as crosstalk from other pads and so on. For example, B will sound but A and C will not sound. If it is set to a high value, no sound may be heard when strike lightly. You can adjust threshold like this: 1. Firstly set it to a low value; 2. Raise the value a little, then strike the pad to check and adjust; 3. Repeat step2 until the most suitable setting for performance has been achieved.
XTALK	1~16	“Crosstalk” means when one pad is hit, another pad would also be triggered, which should be avoided. “XTALK” setting is set for that. Usually this may happen when two pads sit on the same stand. Sometimes crosstalk may be effectively prevented by increasing the distance between two pads. For example: If you hit the snare pad and the tom 1 also sounds. Striking the snare pad, and listen whether there is any sound from Tom 1. If yes, raise Tom1’s “XTALK” value, and repeat this adjusting again until no crosstalk. Note: Be careful and don’t set “XTALK” too high. Because in this situation, when two pads are hit at the same time, the one which is struck gently may be judged as a “crosstalk” and not sound. So it is best to set “XTALK” to the minimum value required to prevent crosstalk.
CURVE	1~6	You can control the relation between striking force and response volume by this setting.
RETRIG		Adjust the curve to satisfy your playing requirement. Refer to the CURVE description.
CANCEL	1~16	This setting avoids “re-triggering”, which means that when you strike a pad once, maybe you can hear two hits coming from one strike. This may happen when pad vibrating. Adjust the “Retrigger Cancel” value and strike the pad to see if there is any re-triggering. Be careful to set it to a suitable value. If too high, some sounds may be omitted when played fast; if too low, retrigger can’t be prevented effectively. It is best to set it to a value just prevented retriggering.
MIDI NOTE	0~127	MIDI output key mapping
SPLASH SENS	1~5	Splash sensitivity. The higher value makes the splash easier.

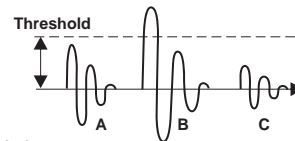

3. Striking the specified pad, select the pad that you want to edit.
4. Use the [<] / [>] button or data dial to adjust the parameter value. When the LCD displays “--”, it means these parameter values are fixed and unchangeable.

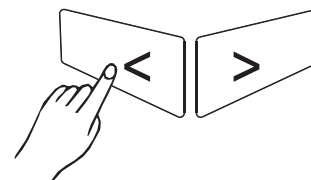

# The Drum Pad Triggers Settings

**Note:**

The Curve descriptions are shown below:

**Curve 1:** The most natural setting. There is a linear change between playing dynamics and volume response.

**Curve 2, 3:** Compared to Curve 1, heavily strikings make greater change.

**Curve 4, 5:** Compared to Curve 1, gentle strikings make greater change

**Curve 6:** Even a soft strike can make strong volume, and the range of dynamic response is small. Especially when a drum trigger is used as an external pad, reliable triggering can be made.

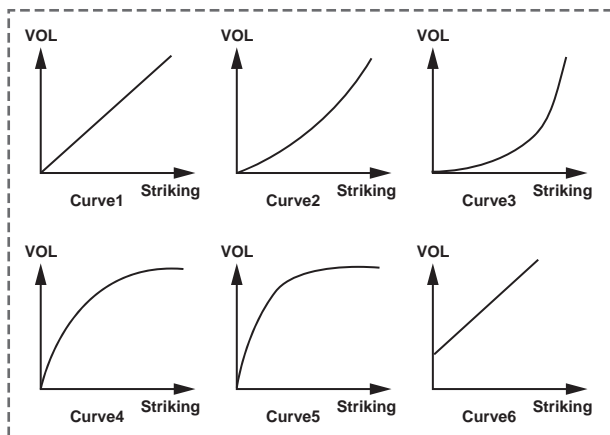

## Save the Drum Pad Trigger Settings

Press [SAVE] button in TRIG menu to save your settings before turn off the power. Otherwise the settings you've edited will be lost.

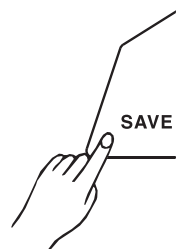

**Note:**

Parameter settings above are efficient to all drum kits.

# Utility Settings

1. In the KIT menu, select the "UTILITY" item.

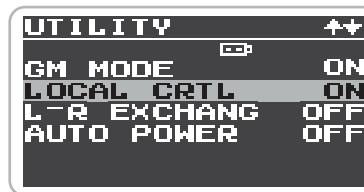

2. Press the [^]/[v] button to select the utility parameters that you want to edit.

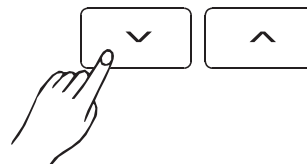

Parameter	Value	Description
GM MODE	ON/OFF	ON: The channel 10 will respond GM drum kit. OFF: The channel 10 will respond local drum kit.
LOCAL CTRL	ON/OFF	Describe the connection state about pad signal and internal sequencer with internal sound generator. ON: The pads and internal sequencer are connected to the digital drum's internal sound generator. Sounds are produced by the internal sound generator when the pads are struck. OFF: The pads and internal sequencer are disconnected from the digital drum's internal sound generator. Striking the pads does not cause sound to be produced by the internal sound generator.
L-R EXCHANG	ON/OFF	Exchange the left and right pad position. R: Normal settings. L: You can exchange the left and right pad position to satisfy the left-hand player.
AUTO POWER	30, 60 ,OFF	Factory settings, approximately 30 minutes. 30: Automatically turns the power off if no operation for approximately 30 minutes. 60: Automatically turns the power off if no operation for approximately 60 minutes. OFF: The power will not power off automatically.

3. Use the [<] / [>] button or data dial to adjust the parameter value.

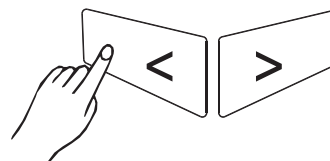

# Using USB Flash Drive (USB Memory)

The USB flash drive function contains:

1. Sample/ Kit load or save. Transmit data between USB flash drive and drum module.
2. Format. Format the USB flash drive.

**Note:**

This digital drum supports 4G~64G USB flash drive which in FAT format. Brand Kinston and SanDisk are suggested.

1. In the KIT menu, select the “USB MEMORY” item. Press the [ENTER] button, enter to the USB flash drive menu.

2. Press the [^]/[v] button to select the USB flash drive function that you want.

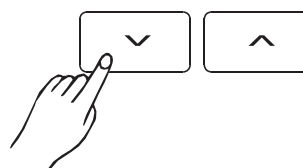
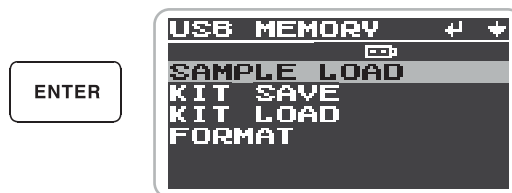

Parameter	Description	Remarks
SAMPLE LOAD	Download wave samples to drum module from the external USB flash drive.	See the note below.
KIT SAVE	Save a user kit data of drum module to the external USB flash drive.	The saved file name is MyKitxxx.kit.
KIT LOAD	Save back a user kit data of USB flash drive to the drum module.	Transmit the MyKitxxx.kit file from the USB flash drive to the drum module.
FORMAT	Format the USB flash drive.	Strongly recommend formatting the USB flash drive once before using it.

## Sample Load

Wave sample on the USB flash drive can be downloaded/saved to the drum module in this function. These voices are called user voices.

1. There is no limitation of sample capacity except exceeding internal memory. Sample's size can reach to 15M Byte.
2. Requirement of Sample wav's format: mono 16 bit, 48k / 44.1k / 32k / 22.05k / 11.025k rate.
3. Samples in internal memory can only be deleted as a whole. One sample deleting is not permitted except that there is only one sample.
4. Both loaded samples and preset voices can be used in the same way.

Enter the “SAMPLE LOAD” interface. The LCD will list all wave files (.wav) which under the sample catalogue. It can display 99 files at most.

Select a sample from the USB flash drive:

Press the [ENTER] button to enter load interface:

Press the [ENTER] button again:

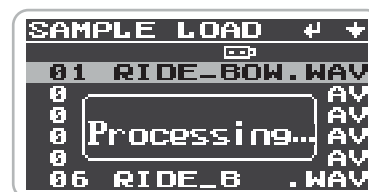
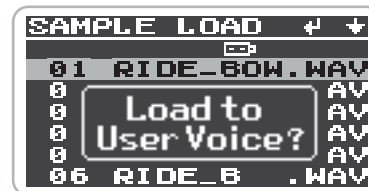
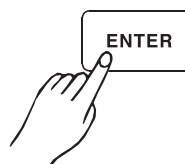
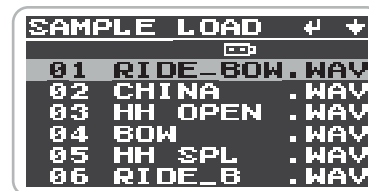

# Using USB Flash Drive (USB Memory)

**Note:**

Loading speed is about XX minutes/MB. More time will be taken when loading larger samples. Please be patient when loading samples. If loading failed, message "Unsupported file" will be displayed on the LCD when the format is not supported.

## Kit Save

User kits of the drum module can be saved to a USB flash drive in this function.

Enter the KIT SAVE interface; the LCD displays kit number and name.

**Note:**

If currently selected kit name is blank, it indicates this kit doesn't exist and can be used to save a user kit. Up to 99 kits can be saved in one folder on the USB flash drive.

Press the [ENTER] button to confirm your selection.

**Note:**

User kit is named "MYKITXXX" in default, and it is unchangeable.

## Kit Load

User kits can be loaded from a USB flash drive to drum module in this function.

Enter the load interface, and the LCD will list kit files (.kit) which under the kit catalogue.

Press the [ENTER] button to confirm your selection.

Select a user kit position to load, and press the [ENTER] button to confirm your selection.

The pop-up box will disappear after a successfully loading, and you can continue downloading other kits.

## Format

A USB flash drive can be formatted in this function. All data in this USB flash drive will be erased, so please backup important data before formatting.

Press [EXIT] button to exit the format menu. Or press [ENTER] button to the next step.

Press [ENTER] button again to confirm your selection.

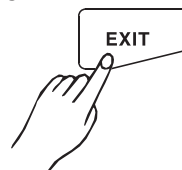
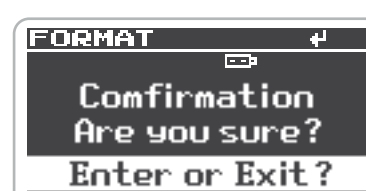
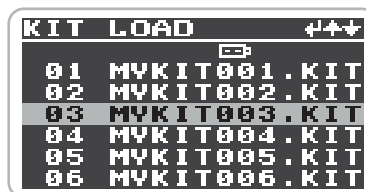
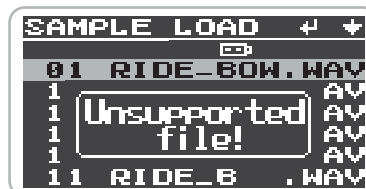
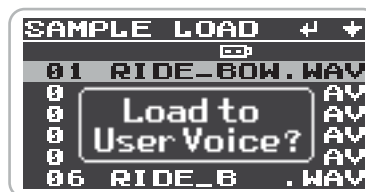

# Factory Set

In this factory set menu, you can initialize all Kit, Song, and Voice settings individually.

1. In the KIT menu, select the "FACTORY SET" item.
2. Press the [^]/[v] and [ENTER] button to select the factory setting that you want to edit.

Parameter	Description
KIT	Only initialize user kit settings.
SONG	Only initialize user songs.
VOICE	Only initialize user voices.
PAD SETTING	Only initialize pad settings.
ALL	Initialize all (above four) user settings.

Press [EXIT] to exit the factory set menu.  
Or press [Enter] to the next step.

After temporal displaying of "Reset OK", it will return to factory set menu.

ENTER

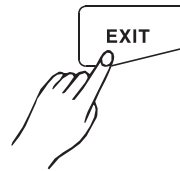

## About MIDI

MIDI (Musical Instrument Digital Interface) is a standard which describes the rules and transmission among all kinds of MIDI devices, including computers. Connecting a digital drum to a computer with a MIDI cable, various instrument can be selected and played, and they also can be played in ensemble.

### MIDI Connection

**MIDI IN:** This terminal receives MIDI data from an external MIDI device.

**MIDI OUT:** This terminal transmits data from the digital drum to other MIDI devices.

### USB Connection

The USB connector allows you to connect the digital drum directly to your computer. It can be connected without installing a driver in Windows XP/Vista/Win7 or MAC OSX environments. The digital drum will be recognized as a “USB Audio device” to receive and transmit MIDI messages through a single USB cable. The USB port is used only for MIDI messages (MIDI via USB).

## Making the MIDI Settings

In the KIT menu, select the “UTILITY” item (Please refer to *Utility Settings* chapter). Press the [^] / [v] button to select the “LOCAL CTRL” or “GM MODE” item.

Use the [+] / [-] button or data dial to set the local control/ GM mode to ON or OFF.

MIDI Settings	
LOCAL CTRL	ON/OFF
GM MODE	ON/OFF

### Local Control

**Local OFF:** The connection from pads and internal sequencer to internal sound generator is cut off. When pads are hitted, no sound will be generated by internal sound generator.

**Local ON:** The connection from pads and internal sequencer to internal sound generator is on. When pads are hitted, sound will be generated by internal sound generator.

### GM Mode

Press the [+] / [-] button, set GM mode to ON or OFF.  
Refer to Using the Digital Drum as a Sound Module.

## Connecting with an External Sound Device

The digital drum transmission channel for the drum kit is fixed to Channel 10. It will output MIDI data generated by the triggers when hitting the pads or stepping on the Hi-Hat control pedal (Note ON/OFF, and Foot messages). Song playback data and metronome notes are not transmitted.

### Recording Your Performance to an External Sequencer

1. Connect the MIDI OUT of the digital drum to the MIDI IN of your sequencer, and the MIDI OUT of your sequencer to the MIDI IN of the digital drum. If you are using a software sequencer on a computer, you can simply connect the USB port of the digital drum to a USB port of your computer using a single USB A-B cable.

# MIDI

2. Setup the active track of your sequencer on Channel 10. Activate RECORD on your sequencer.
3. Play the pads/ Step on the pedal of your digital drum.
4. Stop recording. Locate your sequencer to the start of your recording.
5. Playback the recorded song.

## Setting MIDI Note Number to be Transmitted/Received by Each Pad

Each drum kit has its own settings of MIDI note which can be transmitted/received by each pad, and is very useful for advanced purpose. Normally, we don't recommend changing them, but it still can be changed by following steps:

1. Press the [KIT] button and then [MENU] button, and use [^]/[v] to enter the TRIG menu.
2. Press the [^]/[v] button, select MIDI Note parameter.
3. Use the [<]/[>] button or data dial; change the MIDI Note Number for each pad. Press the [^] button and use the [<]/[>] button or data dial to select the pad that you want to edit. Or you can directly strike the specified pad.
4. Press the [SAVE] button to save the trigger settings.

Trigger	MIDI Note	Trigger	MIDI Note	Trigger	MIDI Note	Trigger	MIDI Note
Kick	36	Tom2 Rim	47	Ride Edge	59	Hi-Hat Open	46
Snare	38	Tom3	43	Ride Bell	53	Hi-hat Edge Open	26
Snare R	40	Tom3 Rim	58	Crash1	49	Hi-Hat Close	42
Tom1	48	Tom4	41	Crash1 Edge	55	Hi-hat Edge Close	22
Tom1 Rim	50	Tom4 Rim	39	Crash2	57	Hi-Hat pedal	44
Tom2	45	Ride Bow	51	Crash2 Edge	52	Splash	21

## Using the Digital Drum as a Sound Module

Connecting an external keyboard or sequencer to the MIDI Input allows you to use the digital drum as a multi-part, polyphonic sound module to play various instrument parts in addition to your drums (for instance, Piano on Channel 1, Bass on Channel 2, Strings on Channel 3, etc). The voices on each MIDI channel are selected using MIDI Program Change messages (refer to **GM Backing Instrument List**).

The MIDI system in the digital drum has 16 reception channels numbered from 1-16. Each of the channels is responsible for a voice. When the instrument receives MIDI information from an external device, the active channel is determined by the control message. Channel 10 is reserved for Drums. The digital drum has two options for Channel 10: GM ON or OFF, as selected in MIDI UTILITY menu.

- When GM Mode is ON, Channel 10 will play the GM percussion kits.
- When GM Mode is OFF, Channel 10 will play the digital drum kit which you select on panel.

### Note:

For more information on receiving MIDI messages, refer to **MIDI implementation chart**.

# Troubleshooting

Problem	Possible Cause and Solution
No sound	1. Rotate the [VOLUME] knob to be sure that the volume isn't down. 2. To be sure that Local Mode should be set to "ON"
No sound from Pads	1. To be sure that the pad is connected correctly. 2. To be sure not set the volume of the pad to 0.
No click sound	1. To be sure that the metronome is turned on. 2. To be sure not set the volume of the click to 0.
The Pad volume doesn't match the Song playback volume.	1. Adjust the song playback volume to match the pad volume.
Cannot connect to the computer	1. Make sure that the USB has been correctly connected. 2. Do the connection again (Keep the computer on, and then turn the module on, connect the USB cable).

# Prompt Messages

Message	Meaning
MEMORY FULL !	The memory of user voice is full when loading samples.
NO SONG FOLDER !	There is no song folder on USB flash drive.
NO SONG !	No song in related song folder on USB flash drive.
NO SAMPLE !	There is not any sound sample in the VOICE folder on USB flash drive.
UNSUPPORTED FILE !	Unsupported file on USB flash drive.
NO USB MEMORY !	USB flash drive is not recognized.
NO KIT !	No kit data in KIT folder on USB flash drive.
RECORD FULL !	Internal memory is full when recording into internal user song.
USB DRIVE ERROR ! PRESS EXIT TO CONTINUE !	The USB flash drive can't be recognized or the object was plugged on USB MEMORY port caused short-circuit.

# Specifications

## Maximum Polyphony

64

## Drum kits

**Kit:** 70 (50 Presets + 20 Users)

**GM Drum Kit:** 9 GM Drum Kits

## Instruments

**Preset voice:** 628 (Drum Voice, Percussion Voice, Effect Voice)

14 Hi-hat Combination

**User voice:** up to 99 samples with 16M Byte in total.

## Sequencer

**Preset Pattern:** 120

**User Song:** 5

**Audio files with mp3 and wav format:** 99 maximum under one folder in USB flash drive.

**Tick:** 192 ticks per beat

**Record:** Real-time Record

**Data Capacity:** About 6800 notes for each user song.

## Tempo

30~280

## Display

64 x 128 dots full lattice LCD display with backlit

## Connectors

TRIGGER INPUT CONNECOR(DB25 type), TOM4, CRASH2, PHONES(1/4"), AUX IN(1/4"), USB-MIDI, USB HOST, MIDI IN, MIDI OUT, R,L/MONO

## Control Buttons

Power on/off, Master Volume, Phones volume, Click, Kit, Save, Record, Song, Start/Stop, Tempo, <, >, Menu, Enter, Exit, ^, v.

## Power Supply

DC 9V, 500mA

## Module Dimensions

230 (L) x 160 (W) x 69 (H) mm

## Module Weight

0.5 kg

\* All specifications and appearances are subject to change without notice.

# Drum Kit List

No.	PRESET KIT
1	Acoustic 1
2	Funk
3	Standard 1
4	JazzBrush
5	Dance
6	Rock
7	Jazz
8	808
9	909
10	FunkBand
11	FX Mix
12	Power
13	Latin
14	Room
15	Marimba
16	Percussion1
17	Metal
18	90'sPower
19	Vibraphone
20	Indian

No.	PRESET KIT
21	African
22	Electronic
23	Reggae
24	Fusion
25	Drum & Bass
26	Pop
27	Brush
28	World
29	Orchestra
30	Ska
31	Songo
32	Lo-Fi
33	1970's
34	HipHop
35	Big Band
36	Old School
37	R&B
38	Magic
39	Live
40	House

No.	PRESET KIT
41	Jazz Latin
42	Standard 2
43	Percussion 2
44	Techno
45	Vintage
46	Junkyard
47	Acoustic 2
48	Noise
49	Studio 1
50	Studio 2

# Drum Voice List

No.	Name
<b>Kick</b>	
1	22" Acoustic Kick 1
2	22" Acoustic Kick 2
3	24" Standard Kick
4	Brush Kick 1
5	Brush Kick 2
6	24" Jazz Kick
7	22" Rock Kick
8	Room Kick
9	Fusion Kick
10	1970's Kick
11	Vintage Kick
12	HipHop Kick
13	Reggae Kick
14	Big Band Kick
15	Old School Kick
16	Lo-Fi Kick
17	Junkyard Kick
18	Noise Kick
19	Drum & Bass Kick
20	808 Kick
21	909 Kick
22	Electronic Kick
23	Power Kick
24	Dance Kick
25	FX Mix Kick
26	Techno Kick
27	Magic Kick
<b>Snare</b>	
28	14" Acoustic Snare
29	14" Acoustic Snare Rim
30	14" Standard Snare
31	14" Standard Snare Rim
32	14" Funk Snare 1
33	14" Funk Snare Rim 1
34	14" Funk Snare 2
35	14" Funk Snare Rim 2
36	Brush Snare 1
37	Brush Snare Rim 1
38	Brush Snare 2
39	Brush Snare Rim 2
40	14" Jazz Snare
41	14" Jazz Snare Rim
42	14" Rock Snare
43	14" Rock Snare Rim
44	13" Damped Snare 1
45	13" Damped Snare 2
46	13" Damped Snare 3
47	Orchestra Snare
48	Orchestra Snare Rim
49	Room Snare
50	Room Snare Rim
51	Fusion Snare
52	Fusion Snare Rim
53	Big Band Snare
54	Big Band Snare Rim

55	Vintage Snare
56	Vintage Snare Rim
57	Live Snare
58	Live Snare Rim
59	Reggae Snare
60	Reggae Snare Rim
61	R&B Snare
62	R&B Snare Rim
63	808 Snare
64	808 Snare Rim
65	909 Snare
66	909 Snare Rim
67	Electronic Snare
68	Power Snare
69	Dance Snare
70	Dance Snare Rim
71	Old School Snare
72	Old School Snare Rim
73	House Snare
74	House Snare Rim
75	Lo-Fi Snare
76	Lo-Fi Snare Rim
77	Junkyard Snare
78	Junkyard Snare Rim
79	Noise Snare
80	Noise Snare Rim
81	Drum & Bass Snare
82	Drum & Bass Snare Rim
83	Techno Snare
84	Techno Snare Rim
85	Magic Snare
86	Magic Snare Rim
87	Acoustic Snare Stick
88	Standard Snare Stick 1
89	Brush Snare Stick
90	Standard Snare Stick 2
91	Rock Snare Stick 1
92	Rock Snare Stick 2
93	Live Snare Stick
94	Room Snare Stick
95	Fusion Snare Stick
96	808 Snare Stick
97	909 Snare Stick
98	Electronic Snare Stick
99	Old School Snare Stick
100	House Snare Stick
101	Lo-Fi Snare Stick
102	Junkyard Snare Stick
103	Noise Snare Stick
104	Techno Snare Stick
105	Brush Swirl
<b>Tom</b>	
106	Acoustic Tom 1
107	Acoustic Tom 1 Rim
108	Acoustic Tom 2
109	Acoustic Tom 2 Rim

110	Acoustic Tom 3
111	Acoustic Tom 3 Rim
112	Acoustic Tom 4
113	Acoustic Tom 4 Rim
114	Acoustic Tom 5
115	Acoustic Tom 5 Rim
116	Acoustic Tom 6
117	Acoustic Tom 6 Rim
118	Standard Tom 1
119	Standard Tom 1 Rim
120	Standard Tom 2
121	Standard Tom 2 Rim
122	Standard Tom 3
123	Standard Tom 3 Rim
124	Standard Tom 4
125	Standard Tom 4 Rim
126	Standard Tom 5
127	Standard Tom 5 Rim
128	Standard Tom 6
129	Standard Tom 6 Rim
130	Brush Tom 1
131	Brush Tom 1 Rim
132	Brush Tom 2
133	Brush Tom 2 Rim
134	Brush Tom 3
135	Brush Tom 3 Rim
136	Brush Tom 4
137	Brush Tom 4 Rim
138	Brush Tom 5
139	Brush Tom 5 Rim
140	Brush Tom 6
141	Brush Tom 6 Rim
142	Funk Tom 1
143	Funk Tom 1 Rim
144	Funk Tom 2
145	Funk Tom 2 Rim
146	Funk Tom 3
147	Funk Tom 3 Rim
148	Funk Tom 4
149	Funk Tom 4 R
150	Funk Tom 5
151	Funk Tom 5 Rim
152	Funk Tom 6
153	Funk Tom 6 Rim
154	Jazz Tom 1
155	Jazz Tom 1 Rim
156	Jazz Tom 2
157	Jazz Tom 2 Rim
158	Jazz Tom 3
159	Jazz Tom 3 Rim
160	Jazz Tom 4
161	Jazz Tom 4 Rim
162	Jazz Tom 5
163	Jazz Tom 5 Rim
164	Jazz Tom 6
165	Jazz Tom 6 Rim

# Drum Voice List

166	Rock Tom 1
167	Rock Tom 1 Rim
168	Rock Tom 2
169	Rock Tom 2 Rim
170	Rock Tom 3
171	Rock Tom 3 Rim
172	Rock Tom 4
173	Rock Tom 4 Rim
174	Rock Tom 5
175	Rock Tom 5 Rim
176	Rock Tom 6
177	Rock Tom 6 Rim
178	Fusion Tom 1
179	Fusion Tom 2
180	Fusion Tom 3
181	Fusion Tom 4
182	1970's Tom 1
183	1970's Tom 2
184	1970's Tom 3
185	1970's Tom 4
186	Vintage Tom 1
187	Vintage Tom 2
188	Vintage Tom 3
189	Vintage Tom 4
190	Vintage Tom 5
191	Vintage Tom 6
192	808 Tom 1
193	808 Tom 2
194	808 Tom 3
195	808 Tom 4
196	808 Tom 5
197	808 Tom 6
198	808 Tom Fx 1
199	808 Tom Fx 2
200	909 Tom 1
201	909 Tom 2
202	909 Tom 3
203	909 Tom 4
204	909 Tom 5
205	909 Tom 6
206	909 Tom 7
207	909 Tom 8
208	Electronic Tom 1
209	Electronic Tom 2
210	Electronic Tom 3
211	Electronic Tom 4
212	Electronic Tom 5
213	Electronic Tom 6
214	Electronic Tom 7
215	Electronic Tom 8
216	Power Tom 1
217	Power Tom 2
218	Power Tom 3
219	Power Tom 4
220	Power Tom 5
221	Power Tom 6
222	90's Power Tom 1

223	90's Power Tom 2
224	90's Power Tom 3
225	90's Power Tom 4
226	90's Power Tom 5
227	90's Power Tom 6
228	Lo-Fi Tom 1
229	Lo-Fi Tom 1 Rim
230	Lo-Fi Tom 2
231	Lo-Fi Tom 2 Rim
232	Lo-Fi Tom 3
233	Lo-Fi Tom 3 Rim
234	Lo-Fi Tom 4
235	Lo-Fi Tom 4 Rim
236	Lo-Fi Tom 5
237	Lo-Fi Tom 5 Rim
238	Lo-Fi Tom 6
239	Lo-Fi Tom 6 Rim
240	Junkyard Tom 1
241	Junkyard Tom 1 Rim
242	Junkyard Tom 2
243	Junkyard Tom 2 Rim
244	Junkyard Tom 3
245	Junkyard Tom 3 Rim
246	Junkyard Tom 4
247	Junkyard Tom 4 Rim
248	Junkyard Tom 5
249	Junkyard Tom 5 Rim
250	Junkyard Tom 6
251	Junkyard Tom 6 Rim
252	Noise Tom 1
253	Noise Tom 1 Rim
254	Noise Tom 2
255	Noise Tom 2 Rim
256	Noise Tom 3
257	Noise Tom 3 Rim
258	Noise Tom 4
259	Noise Tom 4 Rim
260	Noise Tom 5
261	Noise Tom 5 Rim
262	Noise Tom 6
263	Noise Tom 6 Rim
264	Techno Tom 1
265	Techno Tom 1 Rim
266	Techno Tom 2
267	Techno Tom 2 Rim
268	Techno Tom 3
269	Techno Tom 3 Rim
270	Techno Tom 4
271	Techno Tom 4 Rim
272	Techno Tom 5
273	Techno Tom 5 Rim
274	Techno Tom 6
275	Techno Tom 6 Rim
276	Magic Tom 1
277	Magic Tom 1 Rim
278	Magic Tom 2

279	Magic Tom 2 Rim
280	Magic Tom 3
281	Magic Tom 3 Rim
282	Magic Tom 4
283	Magic Tom 4 Rim
<b>Ride</b>	
284	21" Acoustic Ride
285	21" Acoustic Ride Edge
286	21" Acoustic Ride Bell
287	22" Standard Ride
288	22" Standard Ride Edge
289	22" Standard Ride Bell
290	Brush Ride 1
291	Brush Ride 2
292	20" Funk Ride
293	20" Funk Ride Edge
294	20" Funk Ride Bell
295	22" Jazz Ride
296	22" Jazz Ride Edge
297	22" Jazz Ride Bell
298	20" Rock Ride
299	20" Rock Ride Edge
300	20" Rock Ride Bell
301	808 Ride
302	Electronic Ride
303	Electronic Ride Edge
304	Electronic Ride Bell
305	20" Room Ride
306	20" Room Ride Edge
307	20" Room Ride Bell
308	HipHop Ride
309	20" Metal Ride
310	20" Metal Ride Edge
311	20" Metal Ride Bell
312	Old School Ride
313	Old School Ride Edge
314	Old School Ride Bell
315	House Ride
316	House Ride Edge
317	House Ride Bell
318	Vintage Ride
319	Vintage Ride Edge
320	Vintage Ride Bell
321	Lo-Fi Ride
322	Lo-Fi Ride Edge
323	Lo-Fi Ride Bell
324	Junkyard Ride
325	Junkyard Ride Edge
326	Junkyard Ride Bell
327	Noise Ride
328	Noise Ride Edge
329	Noise Ride Bell
330	22" Big Band Ride
331	22" Big Band Ride Edge
332	22" Big Band Ride Bell
333	Techno Ride

# Drum Voice List

334	Techno Ride Edge
335	Techno Ride Bell
<b>Crash</b>	
336	16" Acoustic Crash 1
337	16" Acoustic Crash 1 Edge
338	16" Acoustic Crash 2
339	16" Acoustic Crash 2 Edge
340	16" Standard Crash 1
341	16" Standard Crash 1 Edge
342	16" Standard Crash 2
343	16" Standard Crash 2 Edge
344	Brush Crash 1
345	Brush Crash 2
346	Brush Crash 3
347	Brush Crash 4
348	Funk Crash 1
349	Funk Crash 1 Edge
350	Funk Crash 2
351	Funk Crash 2 Edge
352	19" Jazz Crash 1
353	19" Jazz Crash 1 Edge
354	19" Jazz Crash 2
355	19" Jazz Crash 2 Edge
356	Rock Crash 1
357	Rock Crash 1 Edge
358	Rock Crash 2
359	Rock Crash 2 Edge
360	808Crash
361	909Crash 1
362	909Crash 2
363	Electronic Crash 1
364	Electronic Crash 2
365	Orchestra Crash 1
366	Orchestra Crash 2
367	Orchestra Crash 3
368	Room Crash
369	Room Crash Edge
370	1970's Crash 1
371	1970's Crash 2
372	Old School Crash 1
373	Old School Crash 1 Edge
374	Old School Crash 2
375	Old School Crash 2 Edge
376	Vintage Crash 1
377	Vintage Crash 1 Edge
378	Vintage Crash 2
379	Vintage Crash 2 Edge
380	Lo-Fi Crash 1
381	Lo-Fi Crash 1 Edge
382	Lo-Fi Crash 2
383	Lo-Fi Crash 2 Edge
384	Junkyard Crash 1
385	Junkyard Crash 1 Edge
386	Junkyard Crash 2
387	Junkyard Crash 2 Edge
388	Noise Crash 1
389	Noise Crash 1 Edge

391	Noise Crash 1 Edge
392	Big Band Crash 1
393	Big Band Crash 1 Edge
394	Big Band Crash 2
395	Big Band Crash 2 Edge
396	Techno Crash 1
397	Techno Crash 1 Edge
398	Techno Crash 2
399	Techno Crash 2 Edge
400	Latin Crash 1
401	Latin Crash 1 Edge
402	Latin Crash 2
403	Latin Crash 2 Edge
404	China 1
405	China 1 Edge
406	Splash
407	Splash Edge
<b>HI-HAT</b>	
408	14" Acoustic Hi-hat
409	14" Acoustic Hi-hat Edge
410	14" Acoustic Hi-hat Pedal
411	14" Acoustic Hi-hat Splash
412	14" Standard Hi-hat
413	14" Standard Hi-hat Edge
414	14" Standard Hi-hat Pedal
415	14" Standard Hi-hat Splash
416	Brush Hi-hat
417	Brush Hi-hat Pedal
418	Brush Hi-hat Splash
419	14" Rock Hi-hat 1
420	14" Rock Hi-hat Edge 1
421	14" Rock Hi-hat Pedal 1
422	14" Rock Hi-hat Splash 1
423	14" Jazz Hi-hat
424	14" Jazz Hi-hat Edge
425	14" Jazz Hi-hat Pedal
426	14" Jazz Hi-hat Splash
427	14" Rock Hi-hat 2
428	14" Rock Hi-hat Edge 2
429	14" Rock Hi-hat Pedal 2
430	14" Rock Hi-hat Splash 2
431	808 Hi-hat
432	808 Hi-hat Pedal
433	808 Hi-hat Splash
434	909 Hi-hat
435	909 Hi-hat Pedal
436	909 Hi-hat Splash
437	Dance Hi-hat
438	Dance Hi-hat Pedal
439	Dance Hi-hat Splash
440	Lo-Fi Hi-hat
441	Lo-Fi Hi-hat Edge
442	Lo-Fi Hi-hat Pedal
443	Lo-Fi Hi-hat Splash
<b>Percussion</b>	
444	Maracas

445	Metronome Bell
446	Vibra-slap 1
447	Vibra-slap 2
448	Vibra-slap 3
449	Synthesis Percussion 1
450	Synthesis Percussion 2
451	High Q 1
452	High Q 2
453	Low Q 1
454	Low Q 2
455	Mute Hi Conga 1
456	Mute Hi Conga 2
457	Open Hi Conga 1
458	Open Hi Conga 2
459	Low Conga
460	High Bongo
461	Low Bongo
462	High Timbale 1
463	High Timbale 2
464	High Timbale 2 Rim
465	High Timbale 3
466	High Timbale 3 Rim
467	Low Timbale 1
468	Low Timbale 2
469	Low Timbale 2 Rim
470	Low Timbale 3
471	Low Timbale 4
472	High Agogo
473	Low Agogo
474	Claves
475	Jingle Bell
476	Cowbell
477	Bell Tree 1
478	Bell Tree 2
479	Tambourine
480	Cabasa
481	Long Guiro
482	Short Guiro
483	Indian 1
484	Indian 2
485	Indian 3
486	Indian 4
487	Indian 5
488	Indian 6
489	Indian 7
490	Indian 8
491	Indian 9
492	Indian 10
493	Indian 11
494	Indian 12
495	Indian 13
496	Indian 14
497	Indian 15
498	Indian 16
499	Indian 17
500	African 1

# Drum Voice List

501	African 2
502	African 3
503	African 4
504	African 5
505	African 6
506	African 7
507	African 8
508	African 9
509	African 10
510	African 11
511	African 12
512	African 13
513	African 14
514	African 15
515	African 16
516	Marimba C3
517	Marimba A3
518	Marimba C4
519	Marimba Db4
520	Marimba D4
521	Marimba Eb4
522	Marimba E4
523	Marimba F4
524	Marimba Gb4
525	Marimba G4
526	Marimba Ab4
527	Marimba A4
528	Marimba Bb4
529	Marimba B4
530	Marimba C5
531	Marimba Db5
532	Marimba D5
533	Marimba Eb5
534	Marimba E5
535	Marimba F5
536	Marimba Gb5
537	Marimba G5
538	Marimba Ab5
539	Marimba A5
540	Marimba Bb5
541	Marimba B5
542	Marimba C6
543	Vibraphone G3
544	Vibraphone C4
545	Vibraphone Db4
546	Vibraphone D4
547	Vibraphone Eb4
548	Vibraphone E4
549	Vibraphone F4
550	Vibraphone Gb4
551	Vibraphone G4
552	Vibraphone Ab4
553	Vibraphone A4
554	Vibraphone Bb4
555	Vibraphone B4
556	Vibraphone C5
557	Vibraphone Db5

558	Vibraphone D5
559	Vibraphone Eb5
560	Vibraphone E5
561	Vibraphone F5
562	Vibraphone Gb5
563	Vibraphone G5
564	Vibraphone Ab5
565	Vibraphone A5
566	Vibraphone Bb5
567	Vibraphone B5
568	Vibraphone C6
569	Orchestra Timpani C2
570	Orchestra Timpani Db2
571	Orchestra Timpani D2
572	Orchestra Timpani Eb2
573	Orchestra Timpani E2
574	Orchestra Timpani F2
575	Orchestra Timpani Gb2
576	Orchestra Timpani G2
577	Orchestra Timpani Ab2
578	Orchestra Timpani A2
579	Orchestra Timpani Bb2
580	Orchestra Timpani B2
581	Orchestra Timpani C3
582	Orchestra Timpani Db3
583	Orchestra Timpani D3
584	Orchestra Timpani Eb3
585	Orchestra Timpani E3
586	Orchestra Timpani F3
587	Orchestra Timpani Gb3
588	Orchestra Timpani G3
589	Orchestra Timpani Ab3
590	Orchestra Timpani A3
591	Orchestra Timpani Bb3
592	Orchestra Timpani B3
593	Orchestra Timpani C4
<b>FX</b>	
594	FX 1
595	FX 2
596	FX 3
597	FX 4
598	FX 5
599	FX 6
600	FX 7
601	FX 8
602	FX 9
603	FX 10
604	FX 11
605	FX 12
606	FX 13
607	FX 14
608	FX 15
609	FX 16
610	FX 17
611	FX 18
612	FX 19

613	FX 20
614	One
615	Two
616	Three
617	Four
618	Five
619	Six
620	Seven
621	Eight
622	Nine
623	Ti
624	Ta
625	Ei
626	An
627	E
628	Mute
<b>HI-HAT Combination</b>	
629	Acoustic
630	Funk Band
631	Standard
632	Jazz
633	Jazz Brush
634	Rock
635	808
636	909
637	Dance
638	Marimba
639	Vibraphone
640	Indian
641	African
642	Lo-Fi

# Song List

No.	Name	LCD Name
<b>PATTERN LOOP</b>		
1	Blues Funk	BluesFk
2	Fusion	Fusion
3	Cool Jazz	CoolJazz
4	Ballad	Ballad
5	Samba1	Samba1
6	Retro Hip-Hop	ReHipHop
7	Nu Jazz Funk	NuJazzFk
8	Soul	Soul
9	R&B	R&B
10	Big Band 1	BigBand1
11	Ska	Ska
12	Classic Rock	ClassRk
13	Hardcore Hip-Hop	HaHipHop
14	Retro Dance Pop	DancePop
15	Nu-Metal	Nu-Metal
16	Salsa	Salsa
17	Eu Hip-Hop	EuHipHop
18	Bossa Nova	Bossa
19	Fusion 2	Fusion2
20	8Beat Pop	8BeatPop
21	Jazzy Funk	JazzyFk
22	Swing Big Band	SwBiBand
23	Raggae 1	Raggae1
24	60's Pop	60'sPop
25	Retro Funk	RetroFk
26	Trance	Trance
27	Heavy Rock	HavyRock
28	Swing	Swing
29	Punk	Punk
30	8Beat 1	8Beat1
31	Disco House	DisHouse
32	3/4 Folk	3/4Folk
33	Samba 2	Samba2
34	Latin Rock	LatinRk
35	Reggae 2	Reggae2
36	Dance	Dance
37	Country Pop	CtryPop
38	Country	Country
39	Rock Ballad	RkBallad
40	DancePop	DancePop
41	Bebop	Bebop
42	Rock N'Roll	R'N'R
43	Band Jazz	BandJazz
44	Blues	Blues
45	3/4 Jazz	3/4Jazz
46	80's Metal	80'sMetl
47	Drum N'Bass	D'N'B
48	6/8 Soul	6/8Soul
49	Latin Swing	LtnSwing
50	Funk	Funk
51	Break Beat	BrkBeat
52	Latin Jazz	LtnJazz
53	TripHop	TripHop
54	Brit Pop	Britpop
55	Neo-Thrash	Neo-Thra

56	BigBand 2	BigBand2
57	Mambo	Mambo
58	Shuffle	Shuffle
59	Gtr Bossa	GtrBossa
60	Latin Dance	LtnDance
<b>PERCUSSION LOOP</b>		
61	Indonesia	Indonesi
62	Latin	Latin
63	Bossa	Bossa
64	Samba	Samba
65	3/4 Pop	3/4Pop
66	Pop	Pop
67	Jazz	Jazz
68	Reggae 1	Reggae1
69	Reggae 2	Reggae2
70	Latin Rock	LtnRock
<b>HIT</b>		
71	New Age Tap 1	NewAgeT1
72	New Age Tap 2	NewAgeT2
73	Atmosphere Tap 3	AtmospT3
74	Atmosphere Of Celiet Tap 4	AtmCelT4
75	Polysynth Tap 5	PolysT5
76	Brass Tap 6	BrassT6
77	Pad(warm)Tap 7	WmPadT7
78	Fx Tap 8	FxT8
79	Sweep Tap 9	SweepT9
80	Rock Organ Tap 10	RkOrgT10
<b>TAP</b>		
81	Bass Tap 1	BassT1
82	Synth Bass Tap 2	SynBasT2
83	Bass Tap 3	BassT3
84	Bass Tap 4	BassT4
85	Bass Tap 5	BassT5
86	Swing Bass Tap 6	SwgBasT6
87	Bass Funk Tap 7	BsFunkT7
88	Bass Tap 8	BassT8
89	Bass Tap 9	BassT9
90	Bass Tap 10	BassT10
91	Crystal Tap 1	CrystT1
92	Brightness Tap 2	BrightT2
93	Vibraphone Tap 3	VibraT3
94	Brightness Tap 4	BrightT4
95	Sawtooth Tap 5	SawT5
96	Funk Gtslide Tap 6	FunkGtT6
97	Slap Bass Tap 7	SlapBsT7
98	Chorused Piano Tap 8	ChrPnoT8
99	Fifth Tap 9	FifthT9
100	Melody Tap 10	MeloyT10
101	Brightness Tap 1	BrightT1
102	Rain Tap 2	RainT2
103	Lead Tap 3	LeadT3
104	Sci-fi Tap 4	Sci-fiT4
105	Soundtrack Tap 5	SndtrkT5
106	Funk Gtnote Tap 6	FunkGtT6
107	Slap Bass Tap 7	SlapBsT7
108	Chorused Piano Tap 8	ChoruT8
109	Chorused Piano Tap 9	ChrPnoT9

110	Tenor Sax Tap 10	TeSaxT10
111	Pad Tap 1	PadT1
112	Sci-fi Tap 2	Sci-fiT2
113	Square Tap 3	SqureT3
114	FX8 Tap 4	FX8T4
115	Rain Tap 5	RainT5
116	Funk Gtcut Tap 6	FunkGtT6
117	Bass Fx Tap 7	BassFxT7
118	Chorused Piano Tap 8	ChoruT8
119	Orchestra Hit Tap 9	OrchHtT9
120	Brass Section Tap 10	BrassT10

# GM Drum Kit List

No.	Standard Set(BANK0)	Funk Set(BANK8)	Rock Set(BANK16)	Electric Set(BANK24)	Analog Set(BANK25)
Eb1[27]	High Q	←	←	←	←
E 1[28]	Slap				
F 1[29]	Scratch Push				
F#1[30]	Scratch Pull				
G 1[31]	Sticks				
G#1[32]	Square Click				
A 1[33]	Metronome Click				
Bb1[34]	Metronome Bell				
B 1[35]	Acoustic Bass Drum				
C 2[36]	Bass Drum 1	Funk Kick	Rock Kick Drum	Electric Bass Drum	Analog Bass Drum
C#2[37]	Side Stick				Analog Rim Shot
D 2[38]	Acoustic Snare	Funk Snare 1	Rock Snare Drum1	Electric Snare 1	Analog Snare 1
Eb2[39]	Hand Clap				Analog Clap
E 2[40]	Electric Snare	Funk Snare 2	Rock Snare Drum2	Electric Snare 2	Analog Snare 2
F 2[41]	Low Floor Tom	Funk LowTom2	Rock LowTom2	Electric Low Tom 2	Analog Low Tom2
F#2[42]	Closed Hi-hat				Analog Closed Hi-hat
G 2[43]	High Floor Tom	Funk LowTom1	Rock LowTom1	Electric Low Tom 1	Analog Low Tom1
G#2[44]	Pedal Hi-hat				Analog Pedal Hi-hat
A 2[45]	Low Tom	Funk MidTom2	Rock MidTom2	Electric Mid Tom 2	Analog Mid Tom2
Bb2[46]	Open Hi-hat				Analog Open Hi-hat
B 2[47]	Low-Mid Tom	Funk MidTom1	Rock MidTom1	Electric Mid Tom 1	Analog Mid Tom1
C 3[48]	High Mid Tom	Funk Hi Tom2	Rock HiTom2	Electric Hi Tom 2	Analog Hi Tom2
C#3[49]	Crash Cymbal 1				Analog Cymbal
D 3[50]	High Tom 1	Funk Hi Tom1	Rock HiTom1		Analog Hi Tom1
Eb3[51]	Ride Cymbal 1				
E 3[52]	China Cymbal				
F 3[53]	Ride Bell				
F#3[54]	Tambourine				
G 3[55]	Splash Cymbal				
G#3[56]	Cowbell				
A 3[57]	Crash Cymbal 2				
Bb3[58]	Vibra-slap				
B 3[59]	Ride Cymbal 2				
C 4[60]	High Bongo				
C#4[61]	Low Bongo				
D 4[62]	Mute Hi Conga				
Eb4[63]	Open Hi Conga				
E 4[64]	Low Conga				
F 4[65]	High Timbale				
F#4[66]	Low Timbale				
G 4[67]	High Agogo				
G#4[68]	Low Agogo				
A 4[69]	Cabasa				
Bb4[70]	Maracas				
B 4[71]	Short Whistle				
C 5[72]	Long Whistle				
C#5[73]	Short Guiro				
D 5[74]	Long Guiro				
Eb5[75]	Claves				
E 5[76]	Hi Wood Block				
F 5[77]	LowWood Block				
F#5[78]	Mute Cuica				
G 5[79]	Open Cuica				
G#5[80]	Mute Triangle				
A 5[81]	Open Triangle				
Bb5[82]	Shaker				
B 5[83]	Jingle Bell				
C 6[84]	Bell Tree				
C#6[85]	Castanets				
D 6[86]	Mute Surdo				
Eb6[87]	Open Surdo				

# GM Drum Kit List

No.	Jazz Set(BANK32)	Brush Set(BANK40)	Orchestra Set(BANK48)	Dance Set(BANK56)
Eb1[27]			Closed Hi-hat 2	
E 1[28]			Pedal Hi-hat	
F 1[29]			Open Hi-hat 2	
F#1[30]			Ride Cymbal 1	
G 1[31]				
G#1[32]				
A 1[33]				
Bb1[34]				
B 1[35]			Concert BD 2	
C 2[36]	Jazz Kick 1	Brush Kick 1	Concert BD 1	Dance Bass Drum
C#2[37]				
D 2[38]	Jazz Snare 1	Brush Tap	Concert SD	Dance Snare 1
Eb2[39]			Castanets	
E 2[40]	Jazz Snare 2	Brush Slap	Concert SD	Dance Snare 2
F 2[41]		Brush Low Tom2	Timpani F	Dance Low Tom2
F#2[42]			Timpani F#	Dance Closed Hi-hat
G 2[43]		Brush Low Tom1	Timpani G	Dance Low Tom1
G#2[44]			Timpani G#	Dance Pedal Hi-hat
A 2[45]		Brush Mid Tom2	Timpani A	Dance Mid Tom2
Bb2[46]			Timpani A#	Dance Open Hi-hat
B 2[47]		Brush Mid Tom1	Timpani B	Dance Mid Tom1
C 3[48]		Brush Hi Tom2	Timpani C	Dance Hi Tom2
C#3[49]			Timpani C#	Dance Cymbal
D 3[50]		Brush Hi Tom1	Timpani D	Dance Hi Tom1
Eb3[51]			Timpani D#	
E 3[52]			Timpani E	
F 3[53]			Timpani F	
F#3[54]				
G 3[55]				
G#3[56]				
A 3[57]				
Bb3[58]				
B 3[59]				
C 4[60]				
C#4[61]				
D 4[62]				
Eb4[63]				
E 4[64]				
F 4[65]				
F#4[66]				
G 4[67]				
G#4[68]				
A 4[69]				
Bb4[70]				
B 4[71]				
C 5[72]				
C#5[73]				
D 5[74]				
Eb5[75]				
E 5[76]				
F 5[77]				
F#5[78]				
G 5[79]				
G#5[80]				
A 5[81]				
Bb5[82]				
B 5[83]				
C 6[84]				
C#6[85]				
D 6[86]				
Eb6[87]				

# GM Backing Voice List

PIANO	STRINGS	LEAD
1 Acoustic Grand Piano	41 Violin	81 Lead1 (square)
2 Bright Acoustic Piano	42 Viola	82 Lead2 (sawtooth)
3 Electric Grand Piano	43 Cello	83 Lead3 (calliope)
4 Honky-Tonk Piano	44 Contrabass	84 Lead4 (cliff)
5 E.Piano 1	45 Tremolo Strings	85 Lead5 (charang)
6 E.Piano 2	46 Pizzicato Strings	86 Lead6 (voice)
7 Harpsichord	47 Orchestral Harp	87 Lead7 (fifths)
8 Clavi	48 Timpani	88 Lead8 (bass & lead)
MALLET	STRINGSENSEMBLE	PAD
9 Celesta	49 Strings Ensemble 1	89 Pad1 (newage)
10 Glockenspiel	50 Strings Ensemble 2	90 Pad2 (warm)
11 Music Box	51 Synth Strings 1	91 Pad3 (polysynth)
12 Vibraphone	52 Synth Strings 2	92 Pad4 (choir)
13 Marimba	53 Choir Aahs	93 Pad5 (bowed)
14 Xylophone	54 Voice Oohs	94 Pad6 (metallic)
15 Tubular Bells	55 Synth Voice	95 Pad7 (halo)
16 Dulcimer	56 Orchestra Hit	96 Pad8 (sweep)
ORGAN	BRASS	EFFECTS
17 Drawbar Organ	57 Trumpet	97 FX1 (rain)
18 Percussive Organ	58 Trombone	98 FX2 (soundtrack)
19 Rock Organ	59 Tuba	99 FX3 (crystal)
20 Church Organ	60 Muted Trumpet	100 FX4 (atmosphere)
21 Reed Organ	61 French Horn	101 FX5 (brightness)
22 Accordion	62 Brass Section	102 FX6 (goblins)
23 Harmonica	63 Synth Brass 1	103 FX7 (echoes)
24 Tango Accordion	64 Synth Brass 2	104 FX8 (sci-fi)
GUITAR	REED	ETHNIC
25 Nylon Guitar	65 Soprano Sax	105 Sitar
26 Steel Guitar	66 Alto Sax	106 Banjo
27 Jazz Guitar	67 Tenor Sax	107 Shamisen
28 Clean Guitar	68 Baritone Sax	108 Koto
29 Muted Guitar	69 Oboe	109 Kalimba
30 Overdriven Guitar	70 English Horn	110 Bagpipe
31 Distortion Guitar	71 Bassoon	111 Fiddle
32 Guitar Harmonics	72 Clarinet	112 Shanai
BASS	PIPE	PERCUSSIVE
33 Acoustic Bass	73 Piccolo	113 Tinkle Bell
34 Finger Bass	74 Flute	114 Agogo
35 Pick Bass	75 Recorder	115 Steel Drums
36 Fretless Bass	76 Pan Flute	116 Wood Block
37 Slap Bass 1	77 Blown Bottle	117 Taiko Drum
38 Slap Bass 2	78 Shakuhachi	118 Melodic Tom
39 Synth Bass 1	79 Whistle	119 Synth Drum
40 Synth Bass 2	80 Ocarina	120 Reverse Cymbal
SOUNDEFFECTS		
121 Guitar Fret Noise		
122 Breath Noise		
123 Seashore		
124 Bird Tweet		
125 Telephone Ring		
126 Helicopter		
127 Applause		
128 Gunshot		

# MIDI Implementation Chart

Function...		Transmitted	Recognized	Remarks
Basic Channel	Default	10ch	1 – 16	
	Changed	x	x	
Mode	Default	x	x	
	Messages Altered	x *****	x *****	
Note Number:	True voice	0—127 *****	0—127 0—127	
Velocity	Note on	○ 99H,V=1-127	○	
	Note off	○ (99H,V=0)	○	
After Touch	Key's	x	○	
	Channel's	x	x	
Pitch Bend		x	○	
Control Change	0	x	○	Bank Select
	1	x	○	Modulation
	5	x	○	Portamento Time
	6	x	○	Data Entry
	7	x	○	Volume
	10	x	○	Pan
	11	x	○	Expression
	64	x	○	Sustain Pedal
	65	x	○	Portamento ON/OFF
	66	x	○	Sostenuto Pedal
	67	x	○	Soft Pedal
	80	x	○	Reverb Program
	81	x	○	Chorus Program
	91	x	○	Reverb Level
	93	x	○	Chorus Level
120	x	○	All Sound Off	
121	x	○	Reset All Controllers	
123	x	○	All Notes Off	
Program Change	: True #	○ xxxxxxx	○ 0-127	
System	Exclusive	x	○	
System Common	: Song Position	x	x	
	: Song Select	x	x	
	: Tune	x	x	
System Real Time	: Clock Commands	○ ○	x x	START and STOP only
Aux Messages	: Local ON/OFF	x	x	
	: All Notes OFF	x	x	
Messages	: Active Sense	x	x	
	: Reset	x	x	

O : YES X : NO